

professional



ALKON 50C-70C

COMPACT POWER

Unical

ALKON 50 C - 70 C



ALKON 50 C



ALKON 70 C



WALL HUNG GAS BOILER FOR C.H. LOW NO_x

OUTPUT RANGE	from 50 to 560 kW (in battery)	
EMISSIONS	Class 6 NO _x	
SUPPLY	natural gas / LPG / and mixture of natural gas with 20% of Hydrogen (H ₂)	
MODELS	50 C	70 C
SEASONAL EFFICIENCY	 A	

Heat exchanger in Aluminium / Silicium / Magnesium

**Wall hung installation also in battery (up to 2 batteries of 4 boilers each)
can be combined both with MIXING HEADER and with PLATE HEAT EXCHANGERS**

Product plus values

- **EFFICIENCY CLASS A**
- **CLASS 6 Low NO_x**
thanks to the pre-mix burner with gas-air ratio control which offers a constant CO₂ content for the whole modulation range
- **EFFICIENCY up to 109%**
- **H₂ 20%** (Certified for operation with 20% of hydrogen in the natural gas)
- **POSSIBILITY OF CALIBRATION** according to the thermal need of the installation (it is possible to customize the requested output)
- **CERTIFIED IN OUTPUT RANGE**
- **EXCHANGER / BOILER BODY**
aluminium alloy (Al/Si/Mg)
- **CONTAINED DIMENSIONS**
height 93 cm, width 61.5 and only 26.6 in depth
- **PREMIX COMBUSTION GROUP WITH CONSTANT CO₂** in Al/Si/Mg alloy
- **MICROPROCESSOR PCB**
for boiler control
- **VERY HIGH MODULATION RATIO**
• 1:7 for ALKON 70 • 1:5 for ALKON 50
- **INTEGRAL STANDARD INTERFACE**
for modulating heating controllers with protocol communication (bus-data)
- **COUPLING WITH A MODULATING PUMP HIGH EFFICIENCY** supplied as standard for ALKON 70 and optional for ALKON 50
- **Optional manifold with additional safety devices kit**
- **THERMOREGULATION Ufly P (optional)** and kit Gateway P for remote connection
- **PREDISPOSITION FOR IN BATTERY INSTALLATIONS (optional)**

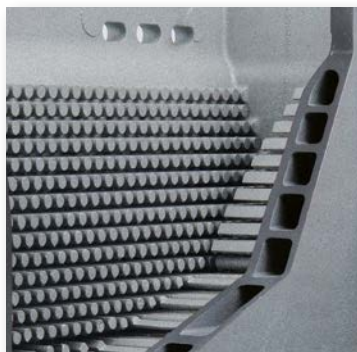

Ultra-compact Boiler body in aluminium alloy (Al/Si/Mg), completely water cooled



Ultra-flat: only 26.6 cm of depth



Combustion always controlled: pneumatic premix and modulating fan



Guaranteed operation also with low gas pressures (down to 13 mbar)



Touch screen Ufly P controller (optional)



Installation of up to 4 modules in battery

Main components

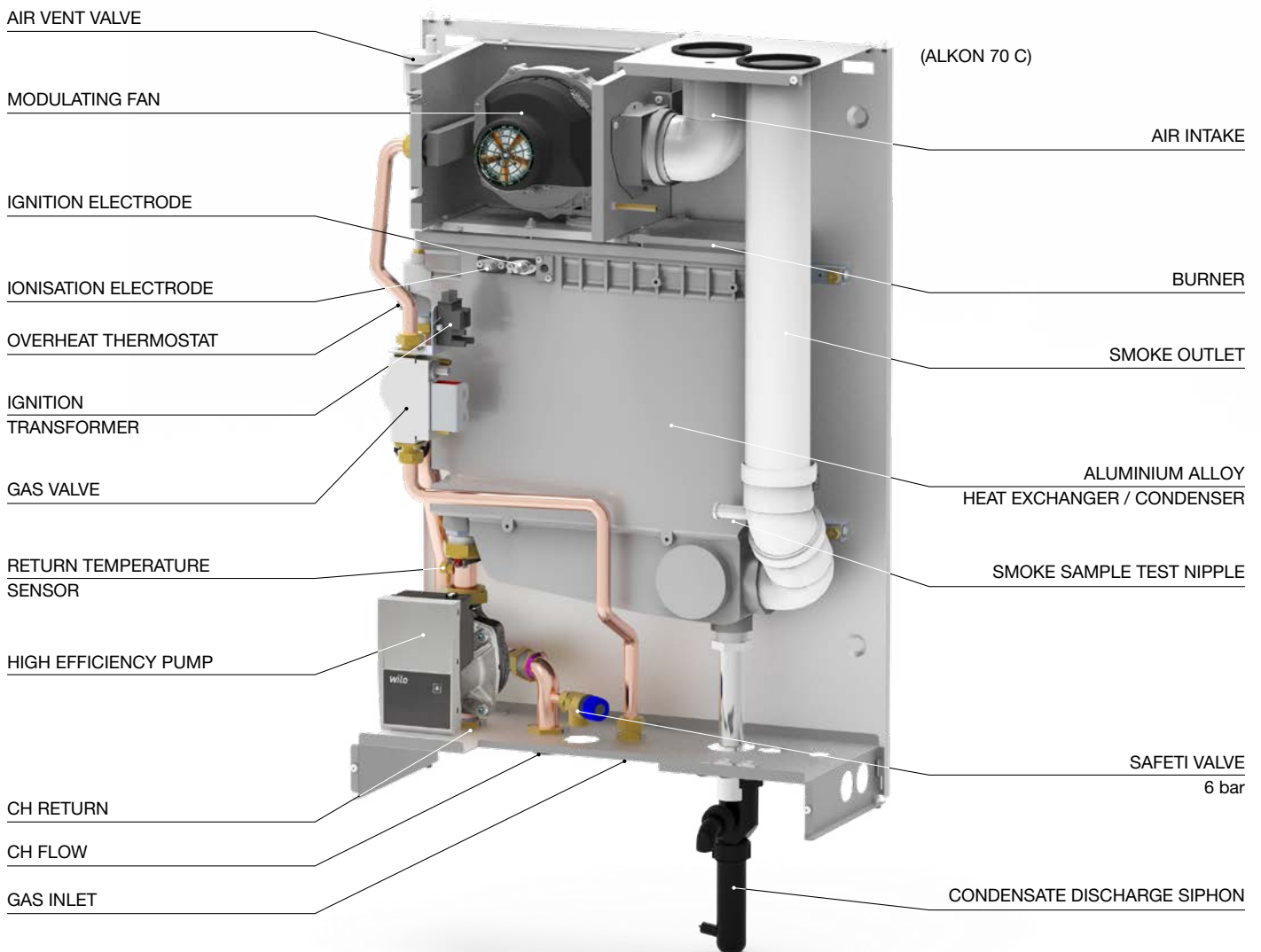

- Total premixing burner with constant CO₂
- Electronic ignition
- Safety limit thermostat
- Flow/return temperature sensor
- Automatic air vent
- Condensate discharge siphon
- Panel board with IPX4D electrical protection degree
- Possibility of e-BUS connection
- C.H. temperature adjustment range 30 to 85°C
- Flame modulation according to the absorbed output
- Pump over-run function
- Additional functions: diagnostic of working parameters and errors, anti-frost, technical service and digital error indication
- Minimum water pressure switch at 0.5 bar
- High efficiency modulating pump
(standard supplied only for ALKON 70)

Optional kits:

- Manifold kit for additional safety devices
- Additional safety devices kit
- Thermoregulation and Control Manager Ufly P
(boiler cascade manager complete with BCM 2.0)
- High efficiency modulating pump kit
(optional for ALKON 50)
- Mixing header / plate heat exchanger kit
- Single chimney / battery
- Supporting frames
- Hydraulic manifolds and blind flanges kit
- Harness kit for external DHW producer

The control panel (standard supplied)

Flexibility of the controls. The control panel is equipped with an alphanumerical display with 6 pre-selection keys, which enable the user to view the following information:

1. Boiler operation

- boiler status; flow and return temperature;
- current error code;

2. User's parameters

- working temperature setting;
- on/off central heating;

3. Service parameters with access code

- maximum working temperature setting;
- selection of thermostat: on/off room thermostat, remote control, on/off or modulating pump;
- pump overrun time;
- fan ignition speed;

4. Data readout

- global flow and return temperatures;
- D.H.W. temperature (if a D.H.W. storage tank is present)

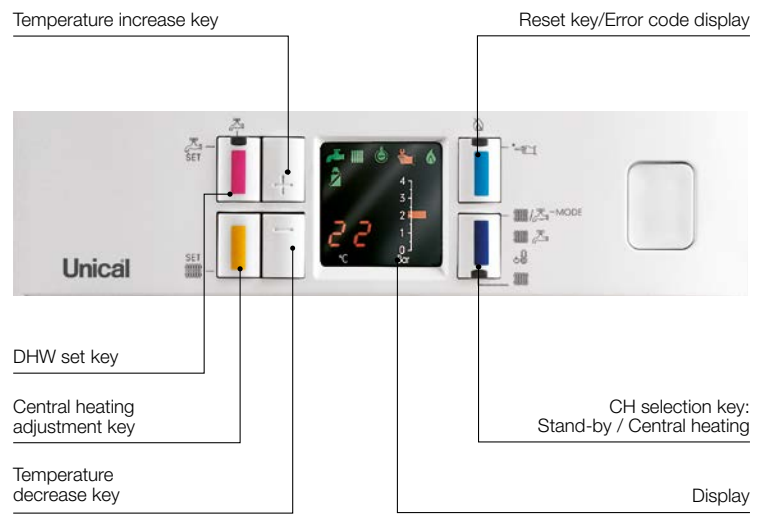

Heating system design with ALKON

The condensing boilers ALKON 50 C and ALKON 70 C permit many types of solutions for every system. A typical layout can be seen below: the low water content boiler faithfully follows the variations of the heating load with maximum fuel saving.

Provision for a pump will have to be made on the basis of the circuit's characteristics and therefore, interface the boiler's various heating loads via the mixing header.

Its various and very important tasks are:

- To make independent the connected circuits.
- To act as "separator" as to permit the separation and collection of the sludge of the system.
- To vent automatically the air contained in the circuits.
- If a D.H.W. storage tank is foreseen, a loading pump must be fitted.

The zones or various C.H. systems, for example in a block of flats with several apartments, can be controlled by the Ufly P thermoregulation, which will manage also the solar integration circuit.

LAYOUT FOR TWO DIRECT/MIXED HEATING ZONES AND D.H.W. PRODUCTION THROUGH SOLAR PANELS

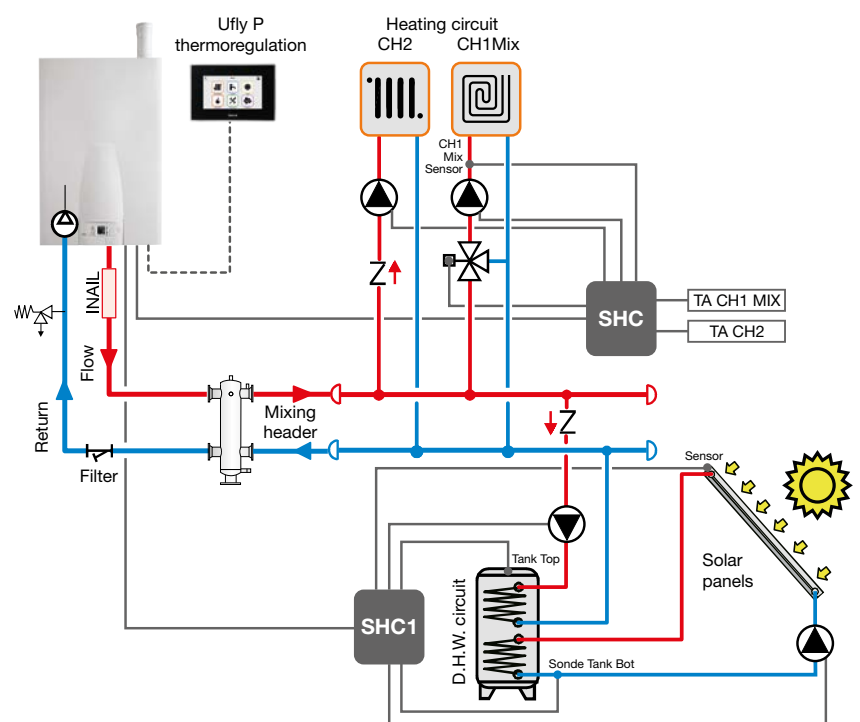

For further information consult the manual on the site www.unical.eu in the section of the product.

Ufly P (optional)

New and powerful interface for the simplified management of professional boilers

Ufly P can be inserted in the control panel, equipped with backlit TFT touch screen Display. The thermoregulation functions allow the hourly weekly scheduling up to a maximum of 12 heating circuits completely independent and of a Domestic Hot Water storage tank (by means of optional SHC cards).

Ufly P checks the **BMM** (Burner Module Manager) for the management of the single thermal element. The regulation of the heating zones and, more generally, of all types of loads, is done through **optional multifunction cards**, called **SHC** (Slave Heating Controller) for the circuits CH, DHW and the auxiliary resources (timed relays, solar accumulators).

TYPE CONFIGURATION OF A SINGLE BOILER

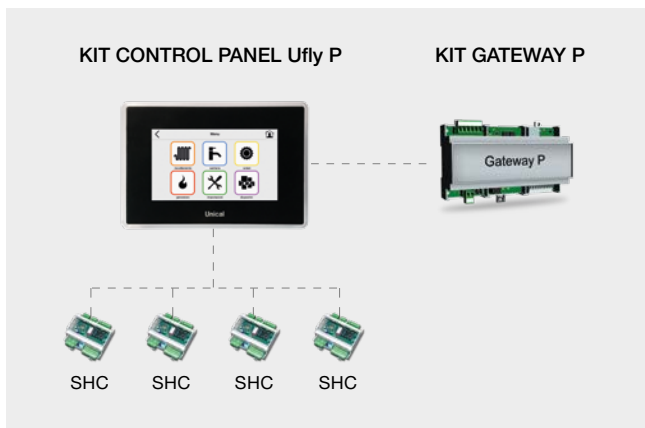

Telemangement

Alternatively, there are available 2 different communication protocols: **eBUS** and **Modbus**, intended for connection to different control devices.

- Acquisition of operational information of all the connected devices
- Parameters Setting / Changing of each module
- Diagnostic management: alarm Acquisition and Reset
- Gateway: allows the conversion of the Modbus / eBUS protocol to access all resources connected to the local eBUS

Included: Outdoor temperature sensor

Mounted: Flow temperature sensor, return temperature sensor.

TYPE CONFIGURATION OF BOILERS IN BATTERY

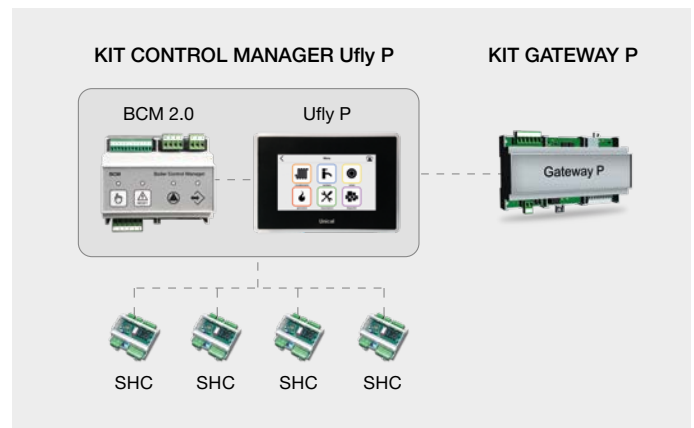

Remote Control (optional)

Ufly APP allows the Unical heating system to be controlled remotely from smartphone or tablet. It allows you to programme and control your heating system from a distance by connecting the system to the home network and thanks to the pairing system integrated to the APP and UFLY P you can create a perpetual connection between your devices and the boilers.

Details of the main functions of the Ufly APP:

- **HEATING and DOMESTIC HOT WATER**
Daily and Weekly Programming the heating system circuits and domestic hot water
- **BOILER**
You can check the status of the boiler by verifying whether it is activated for the heating system or for the domestic hot water system, in addition to other useful information related to the system.
- **SOLAR**
You can view the status of the solar heating system, if installed, and turn it on or off.

■ ERROR STATUS

You can view the history of the errors generated by the system and RESET the system which will resolve the problem directly by simply restarting the system itself in the case of critical errors.

■ NOTIFICATIONS

If a problem occurs in the system, you will be immediately notified with a push notification and, if the failure is not immediately resolved by RESETTING, you can contact the Technical Assistance and report the displayed error.



Composition single boiler + primary ring

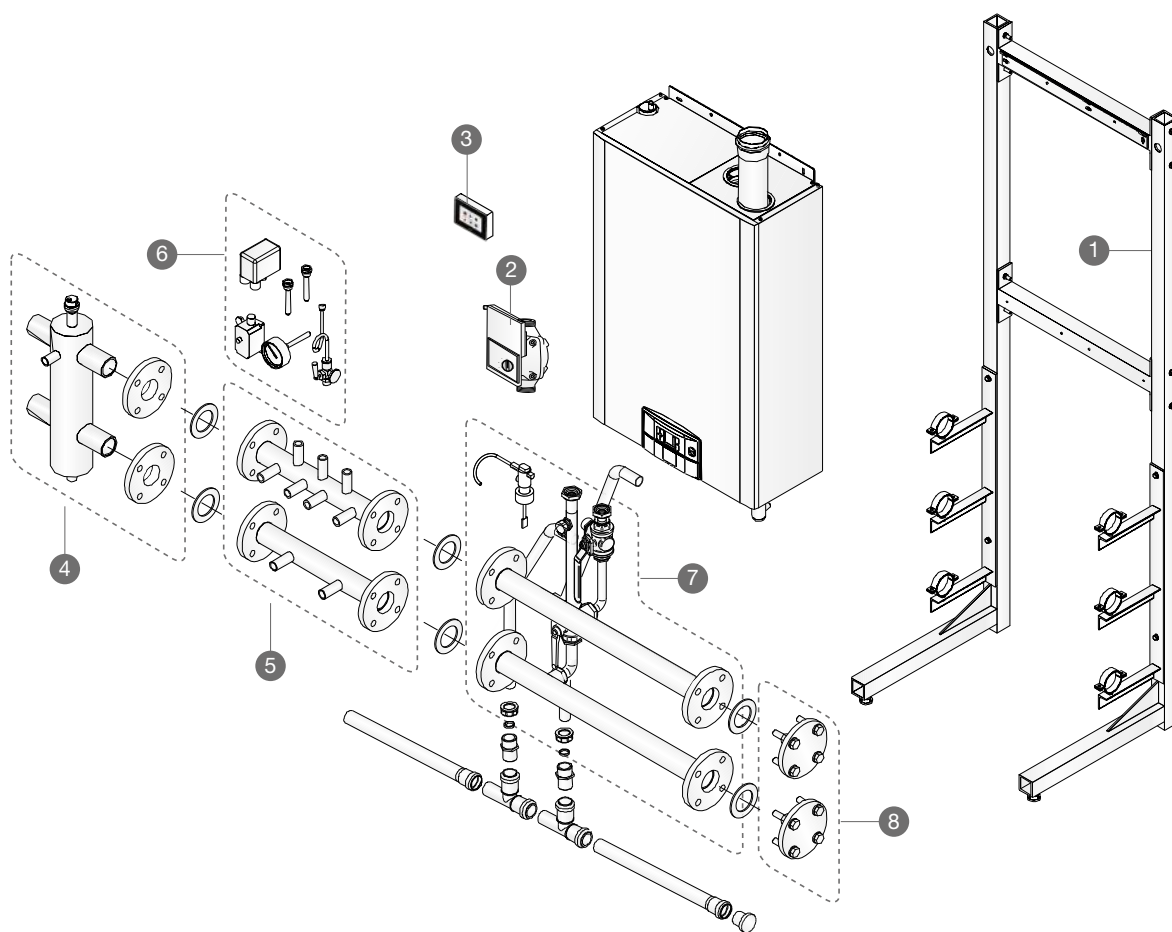

COMPONENTS (optional)

- 1 - SUPPORTING FRAME FOR ONE MODULE
- 2 - MODULATING PUMP high efficiency (optional for ALKON 50: to be ordered separately)
- 3 - KIT CONTROL PANEL Ufly P
composed of: thermoregulation Ufly P, Outdoor temp. sensor
- 4 - MIXING HEADER KIT (maximum flow rate 6 m³/h)
- 5 - ADDITIONAL SAFETY DEVICES COLLECTOR KIT
- 6 - ADDITIONAL SAFETY DEVICES KIT
composed of: 3-way cock 1/2", pressure gauge R 3/8, R 1/2 bulb holders (2x), 100°C H.L. thermostat, 5 bar safety max pressure switch, thermometer, shock absorber for pressure gauge.
- 7 - COLLECTORS KIT
costituito da: composed of: Ballstop valves, 3 way valve, Flow collector, Return collector, Return pipe connection, Differential pressure switch, Flow pipe connection
+ differential pressure switch
- 8 - BLIND FLANGES KIT

NOTE: the gas feeding pipes are not supplied

REGULATION ACCESSORIES (optional)

- SHC MULTIFUNCTION MODULE (for zones management)
+ 3 control probes (it is possible to drive up to a maximum of 4 SHC cards)
- NTC sensor for SHC Module
- Probe PT 1000 for management of solar collectors
- KIT GATEWAY P for Ufly P remote connection
- ROOM TEMPERATURE SENSOR KIT

Available in combination with PLATE HEAT EXCHANGERS

Batteries for large size installations

Integration and perfect compatibility

ALKON multiplies itself!

The flexible Ufly P thermoregulation via the e-Bus connection system permits the management, with only two wires, of up to 8 ALKON units.

Subdivided in two banks of 4 boilers each, they can supply a total output of up to 560 kW (with 8 ALKON 70 C) and up to 400 kW (with 8 ALKON 50 C), with a subsequent flexibility of use.

Suitable hydraulic connection kits, approved flue outlet systems, easy to mount frames and all the ADDITIONAL SAFETY DEVICES in order to present the system approved by Unical, permits the fast installation of the complete circuit with a mixing header, suitably dimensioned for the designed output.

This gives you the advantage of having at disposal, where space is very reduced, high efficiency modules, guaranteeing:

- Recovery and restoration of old heating plants
- Better efficiency levels thanks to the excellent modulation ratio which reduces the output in all the boilers, proportionally to the output required and shuts them down in sequence.
- Reliable operation under every condition thanks to output sharing.

The versatility of combinations which the ALKON modular system offers, is practically endless.

In this case you can choose an ALKON as the “master” boiler who, via the Ufly P thermoregulation, “controls” the subsequent ALKON “slave” boilers, who are also equipped with a pump. Choosing from the accessories available, the multiple arrangement of boilers will be constructed on the basis of the C.H. system’s requirements.

Each boiler can be fitted with a single flue outlet configuration which, then, conveys the flue gases into a sole collector.

The above applications are approved and certified according to the existing Standards.

Flexible operation and high operating efficiencies

We have seen that the individual ALKON boiler has an approved **efficiency** which, when the output reduces, increases progressively **up to 107%** (in condensing mode).

This is possible because on the heat exchanger with the same surface, a smaller input is more easily absorbed, with a contemporaneous smoke temperature reduction.

In order to increase the total operating efficiency of the ALKON, the Ufly P thermoregulation maintains the major number of ALKON units in the multiple boiler installation, firing at the **lowest possible rate** (as shown in the below examples).

Using this method the heating system will always operate at the **maximum possible efficiency**, independently from the output supplied.

Always with the same operation principle, when the heating load slowly reduce itself, the output of each module will also be controlled and proportionally reduced.

As the minimum rate of each module is 10 kW, if the required load is inferior to the total minimum output of the single units (n° units x 10 kW), only the ALKON boilers, needed to reach the requested output at the maximum efficiency level, will be fired and the other units will be shut down.

Moreover, in order to ensure an equal daily rotation of each module, every 24 hours each unit will be fired alternately, so as to ensure that each one operates for the same number of hours.

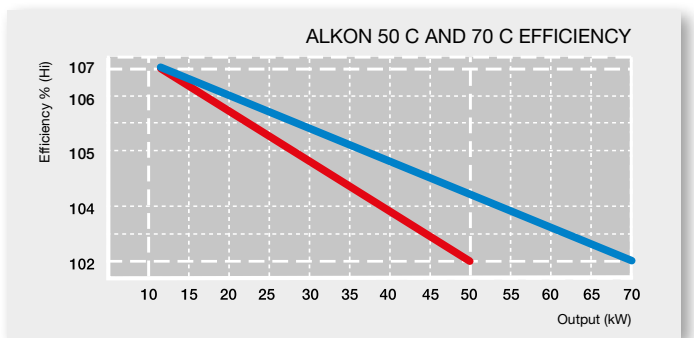

Output sharing with 4 x 50 kW modules in cascade

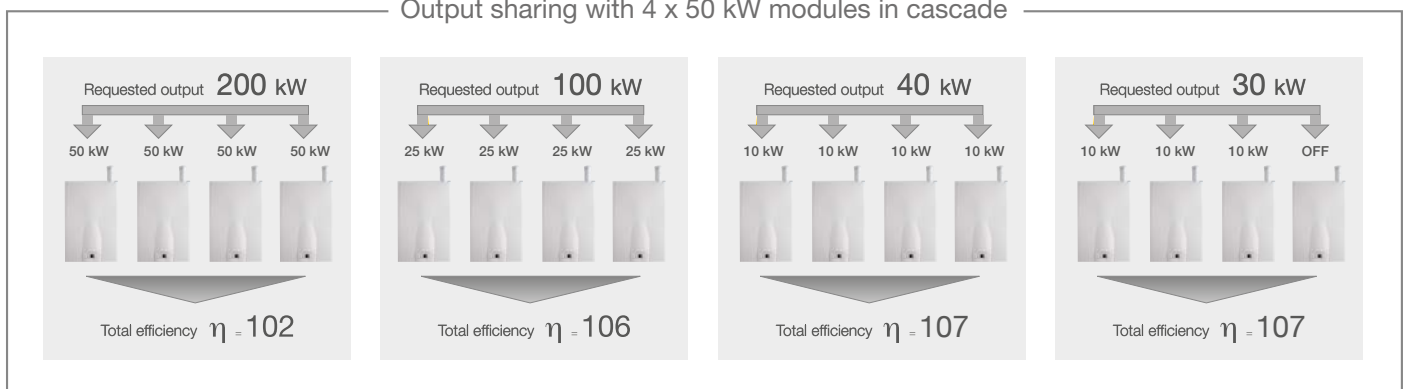

Composition of the battery + primary ring*



	NUMBER OF UNITS IN BATTERY					
	2 UNITS		3 UNITS		4 UNITS	
	ALKON 50 quantity	ALKON 70 quantity	ALKON 50 quantity	ALKON 70 quantity	ALKON 50 quantity	ALKON 70 quantity
1 - ALKON 50 C metano / g.p.l.	2		3		4	
- ALKON 70 C metano / g.p.l.		2		3		4
2 - Kit CONTROL MANAGER Ufly P	1	1	1	1	1	1
3 - SUPPORTING FRAME FOR 2 UNITS	1	1	1	1	1	1
3a - EXPANSION FRAME FOR 1 UNIT			1	1	2	2
4 - COLLECTORS KIT + differential pressure switch	2	2	3	3	4	4
5 - ADDITIONAL SAFETY DEVICES KIT STUB PIPE	1	1	1	1	1	1
6 - ADDITIONAL SAFETY DEVICES KIT	1	1	1	1	1	1
7 - HYDRAULIC SEPARATOR KIT UP TO 150 kW	1	1	1			
- HYDRAULIC SEPARATOR KIT FROM 180 TO 450 kW				1	1	1
8 - SEPARATOR CONNECTION KIT UP TO 150 kW	1	1	1			
- SEPARATOR CONNECTION KIT FROM 180 TO 450 kW				1	1	1
9 - FLUE OUTLET KIT 2 ALKON UNITS DN 160	1	1	1	1	1	1
9a - EXPANSION FLUE OUTLET KIT 1 ALKON UNIT DN 160			1	1	2	2
- SMOKE THERMOSTAT KIT	2	2	3	3	4	4
10 - BLIND FLANGE KIT	1	1	1	1	1	1
- MODULATING PUMP (optional for ALKON 50)	2		3		4	

Note: all the assembly of evacuation system and the additional accessories are in certified translucent Polypropylene. The gas supply pipes are not supplied.
Available in combination with PLATE HEAT EXCHANGERS

*For the configurations refer to the Technical Manual for Use and Maintenance on the web site www.unical.eu

Dimensions

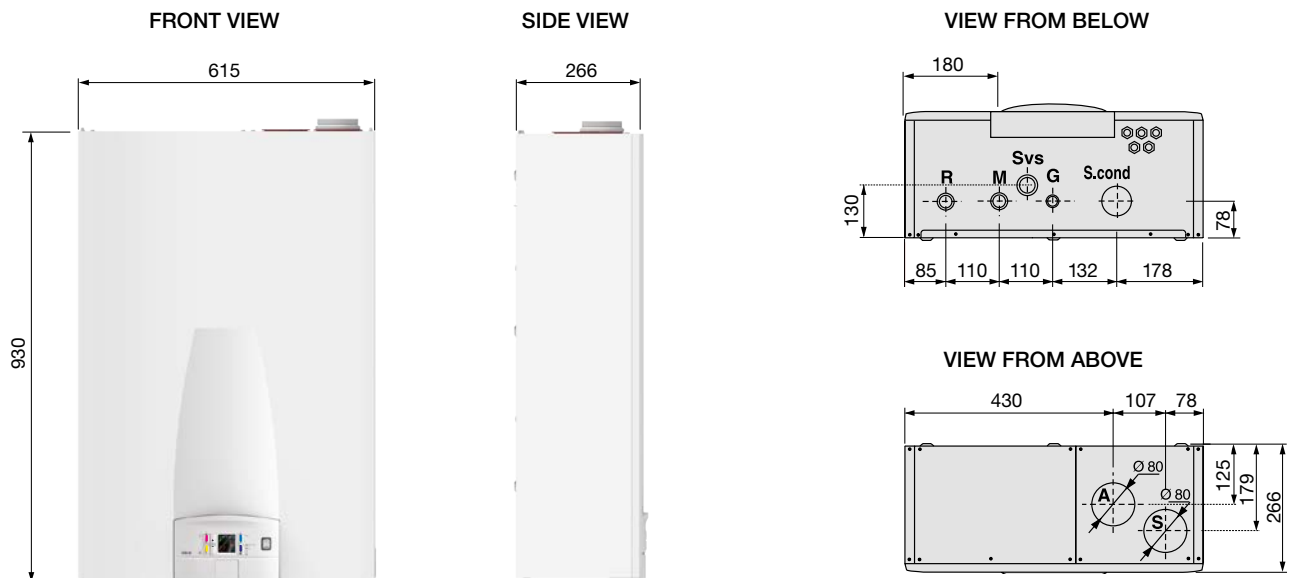

Key:

- | | |
|--|-----------------------------------|
| R - Heating system return
(G1" for mod. 50, G1 1/4" for mod. 70) | G - Gas inlet (G 3/4") |
| M - Heating system flow
(G1" for mod. 50, G1 1/4" for mod. 70) | Scond - Condensation drain |
| | A - Air Suction |
| | S - Exhaust Smoke |

ALKON	Net Weight kg	Gross Weight (with packaging) kg
50 C	50	55
70 C	58,4	64

For further information consult the manual on the site www.unical.eu in the section of the product.

Data according to ErP directive

ELECTRICAL, HYDRAULIC, INSTALLATION DIAGRAMS AND CONTROLLERS can be unloaded from the web site www.unical.eu at the page of the product

			ALKON 50 C	ALKON 70 C
NOMINAL HEAT OUTPUT	P_n	kW	47	66
SEASONAL SPACE HEATING ENERGY EFFICIENCY	η_s	%	93	93
SEASONAL EFFICIENCY CLASS IN HEATING MODE			A	A
FOR CH ONLY AND COMBINATION BOILERS: USEFUL HEAT OUTPUT				
USEFUL HEAT OUTPUT in high temperature regime (Tr 60°C / Tm 80°C)	P_4	kW	47.2	65.7
USEFUL EFFICIENCY AT NOM. HEAT OUTPUT in high-temperature regime (Tr 60°C / Tm 80°C)	η_4	%	87.7	87.7
USEFUL HEAT OUTPUT AT 30% OF NOM. HEAT OUTPUT in low-temperature regime (Tr 30°C)	P_1	kW	15.7	21.9
USEFUL EFFICIENCY AT 30% OF NOM. HEAT OUTPUT in low-temperature regime (Tr 30°C)	η_1	%	97.1	97.3
RANGE-RATED BOILER: YES / NO			NO	NO
AUXILIARY ELECTRICITY CONSUMPTION				
AT FULL LOAD	$e_{l_{max}}$	kW	0.203	0.267
AT PART LOAD	$e_{l_{min}}$	kW	0.162	0.172
IN STAND-BY MODE	P_{SB}	kW	0.005	0.005
OTHER ITEMS				
STAND-BY HEAT LOSS	P_{stby}	kW	0.151	0.151
EMISSIONS OF NITROGEN OXIDES referred to GCV	NO_x	mg/kWh	41	42
NO_x CLASS			6	6
INSIDE SOUND POWER LEVEL	Lwa	dB(A)	60	63

Technical data

ELECTRICAL, HYDRAULIC, INSTALLATION DIAGRAMS AND CONTROLLERS can be unloaded from the web site www.unical.eu at the page of the product

		ALKON 50 C	ALKON 70 C
Appliance category		II _{2H3P}	II _{2H3P}
Modulation Ratio		1:5	1:7
Nominal Heat Input on P.C.I. Q _n	kW	48.5	67.5
Minimum Heat Input on P.C.I. Q _{min}	kW	9.6	9.6
Nominal input on N.C.V. Q _n with mixture of 80% NG + 20% H ₂	kW	43,2	62,4
Minimum input on N.C.V. Q _{min} with mixture of 80% NG + 20% H ₂	kW	8,5	8,5
Nominal Output (Tr 60 / Tm 80 °C) P _n	kW	47.2	65.7
Minimum Output (Tr 60 / Tm 80 °C) P _n min	kW	9.1	9.1
Nominal Output (Tr 30 / Tm 50 °C) P _{cond}	kW	49.4	68.7
Minimum Output (Tr 30 / Tm 50 °C) P _{cond} min	kW	10.04	10.33
Efficiency at max. output (Tr 60 / Tm 80°C)	%	97.29	97.29
Efficiency at min. output (Tr 60 / Tm 80°C)	%	94.9	94.9
Efficiency at max. output (Tr 30 / Tm 50°C)	%	101.82	101.72
Efficiency at min. output (Tr 30 / Tm 50°C)	%	104.55	107.58
Efficiency at 30% output (Tr 30°C)	%	107.33	107.33
Combustion efficiency with nominal load	%	97.82	97.38
Combustion efficiency with minimum load	%	98.51	98.34
Heat loss at casing with burner in operation (Q _{min})	%	3.60	3.44
Heat loss at casing with burner in operation (Q _n)	%	0.52	0.09
Flue gas temperature tf-ta (min)(*)	°C	30.6	34
Flue gas temperature tf-ta (max)(*)	°C	43.6	51.3
Maximum allowable temperature	°C	100	100
Maximum operating temperature	°C	85	85
Flue gas mass flow rate (min)	kg/h	15.9	16
Flue gas mass flow rate (max)	kg/h	80.0	106.5
Excess λ air	%	25.53	20.6
Flue losses with burner in operation (min)	%	1.49	1.66
Flue losses with burner in operation (max)	%	2.18	2.62
Minimum heating circuit pressure	bar	0.5	0.5
Maximum heating circuit pressure	bar	6	6
Water content	l	3.9	3.9
Gas Consumption Natural gas G 20 (supply pressure 20 mbar) @ Q _n	m ³ /h	5.13	7.14
Gas Consumption Natural gas G 20 (supply pressure 20 mbar) @ Q _{min}	m ³ /h	1.02	1.02
Gas Consumption with mixture of 80% NG + 20% H ₂ (supply pressure 20 mbar) @ Q _n	m ³ /h	5.95	8.27
Gas Consumption with mixture of 80% NG + 20% H ₂ (supply pressure 20 mbar) @ Q _{min}	m ³ /h	1.18	1.18
Gas Consumption G25 (supply pressure 25 mbar) @ Q _n	m ³ /h	5.96	8.30
Gas Consumption G25 (supply pressure 25 mbar) @ Q _{min}	m ³ /h	1.18	1.18
Gas Consumption G31 (supply pressure 37/50 mbar) @ Q _n	kg/h	3.76	5.24
Gas Consumption G31 (supply pressure 37/50 mbar) @ Q _{min}	kg/h	0.75	0.75
Max. available pressure at the chimney base	Pa	70	70
Condensate production max	kg/h	7.8	10.87
Emissions			
CO at Minimum Heat Input with 0% of O ₂	mg/kWh	71.3	82
NO _x at Nominal Heat Input with 0% of O ₂	mg/kWh	56	59
Electrical Data			
Voltage/Frequency electric power supply	V/Hz	230/50	230/50
Fuse on main supply	A (R)	6	6
Insulation degree	IP	X4D	X4D

Room Temperature = 20°C.

(*) Temperatures detected with the unit in operation (Tr 60°C / Tm 80°C)

Seasonal Efficiency η_s according to Directive 2009/125/EC for Outputs < = 400 kW. See Erp Table

Standstill heat losses at Δt 30K - P_{std} - See Erp Table

Standstill electrical consumption - P_{sb} - See Erp Table

